

View without cover

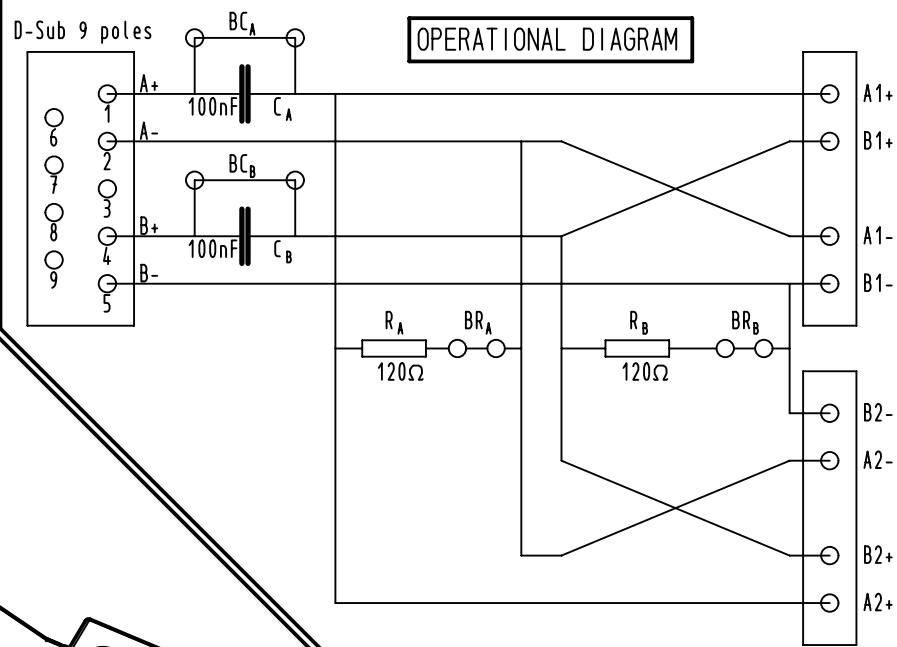
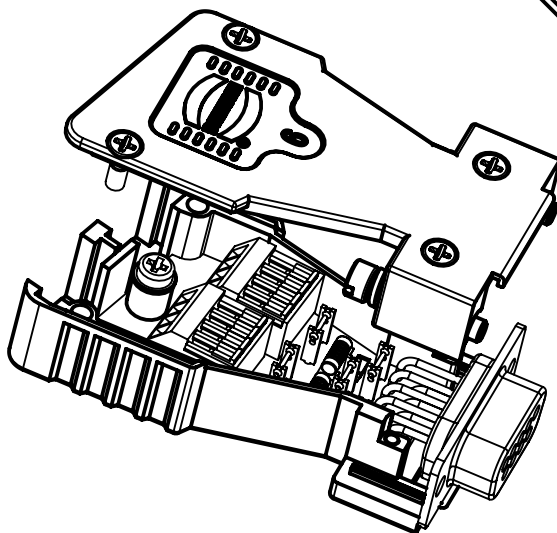
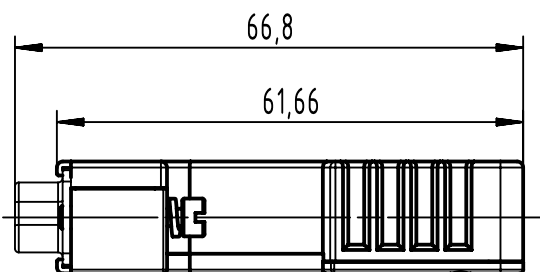
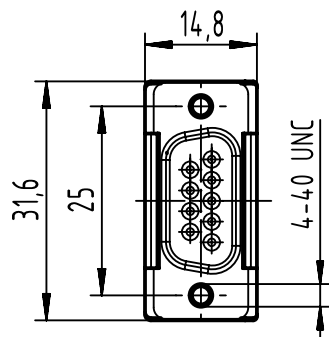
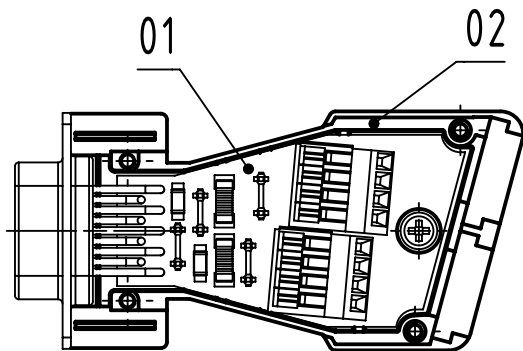

In set inclusive:

| Number | Description |
|--------|------------------------|
| 2 | Crimp flange 5,5-6,5 |
| 2 | Crimp ferrule 9,5-10,5 |
| 1 | blanking piece 9-37 |
| 1 | lable line A, B |

| | | |
|-------------------|-------------------|----------------|
| 6663 009 6040 777 | PL2 | Small batch |
| 6663 009 6040 | PL2 | Standard batch |
| Part number | Performance level | Remark |

| | | | | | | |
|------------------------------|---|--|-----------------------|---------------------------|---|------------------------|
| | All rights reserved Department EL PD | All Dimensions in mm Original Size DIN A4 | | Scale 1:1 | Free size tol. | Ref. |
| | | Created by ZHUANGJ | Inspected by LUOK | Standardisation ROEBEN | Date 2021-08-04 | State Final Release |
| HARTING D-32339 Espelkamp | | Title InduCom 9 Female MVB/WTB 4-40UNC | | | Doc-Key / ECM-Nr. 100075722/UGD/007/C 5300000208533 | |
| | | Type TB | Number 66630096040 | | Rev. C | Page 1/1 |